



[Complete Transmissions](#) | [Gear Sets](#) | [5 speed conversions](#) | [Hot Rod Oil](#) | [Print this Page](#)

Products & Services

We can provide New Tremec Transmissions for your Classic Car, Muscle Car, Street Rod or Truck. These transmissions are perfect for 4 to 5 or 6 speed conversions or an automatic to manual swaps. Not only do we sell new units, we can rebuild your transmission and provide upgrades for power increases and performance. We will do a complete 5 or 6 speed conversion, or provide the parts and technical assistance for you. **NEW! Hot Rod Oil [Click Here](#)**



Complete Transmissions



8 Optional Shifter Locations
Tremec offset shifter
for 500 & 600

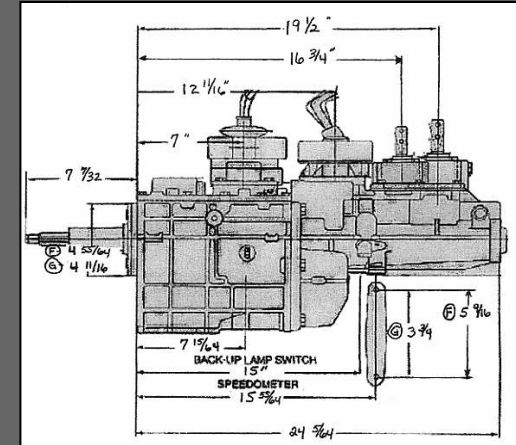

Tremec TKO 500 & 600

[back to top](#)



TKO 500 & 600

Part #	Customer	Splines		Torque Lb Ft	Gear Ratios							Weight Lbs.	Install Inches
		I	O		1	2	3	4	5	6	Rev		
TCET5201	Ford	26	31	500	3.27	1.98	1.34	1	0.68	n/a	3.00	105	31.24
TCET4615	Ford	10	31	500	3.27	1.98	1.34	1	0.68	n/a	3.00	105	31.24
TCET4616	GM	26	31	500	3.27	1.98	1.34	1	0.68	n/a	3.00	105	31.24
TCET4617	Ford	26	31	600	2.87	1.89	1.28	1	0.82	n/a	2.56	105	31.24
TCET4618	GM	26	31	600	2.87	1.89	1.28	1	0.82	n/a	2.56	105	31.24
TCET5008	Ford	26	31	600	2.87	1.89	1.28	1	0.64	n/a	2.56	105	31.24
TECT5009	GM	26	31	600	2.87	1.89	1.28	1	0.64	n/a	2.56	105	31.24

Tremec Options



Off Set Shifter



Mid Shifter



Shifter Stops,
add stops to Stock Shifter

[back to top](#)

T-5

Item		Price
New Z Spec	2.95 1st gear	Call
Rebuilt Z Spec	2.95 1st gear	899.00
Rebuilt 335 Cobra	3.35 1st Gear	799.00
Rebuilt Stock		Call



T-56

Part #	Customer	Application	Spline		Torque Lb Ft	Gear Ratios							Weight Lbs.	Install Inches
			I	O		1	2	3	4	5	6	Rev		
1386-000-011	Aftermarket	GM	26	27	400	2.97	2.07	1.43	1	0.80	0.62	3.28	110	26.26
1386-000-012	Aftermarket	Mustang	10	31	400	2.97	2.07	1.43	1	0.80	0.62	3.28	129	32.47

Camaro 5 Speed Kit



TKO 600 Transmission
67 -69 Camaro Cross Member
Rear transmission Mount
31 Spline X Long HD Yolk
Speedometer Adapter & Gear
\$2495.00

Mustang 5 Speed Kit - 1965 - 1973

T5 Z Spec Transmission
Adapter Plate, T5 to 4 Speed Bell
Cross Member
Rear transmission Mount
28 Spline X Long HD Yolk



Speedometer Gear

\$1775.00

[back to top](#)

Speedometer Gears and Adapters



Speedometer Gears and Adapters for
Tremec Trans. Ford & GM

Item #	Description	Price
CGT0014	GM Speedometer Cable Adapter for Tremec Trans.	\$65.00
CGT0016	16 T Speedometer gear	\$11.00
CGT0017	17 T Speedometer gear	\$11.00
CGT0018	18 T Speedometer gear	\$11.00
CGT0019	19 T Speedometer gear	\$11.00
CGT0020	20 T Speedometer gear	\$11.00
CGT0021	21T Speedometer gear	\$11.00
CGT0023	23 T Speedometer gear	\$14.00



G-Force Gear Sets



T-5 with G-Force Gear Sets. The little transmission that can handle big HP. This is a great transmission for every Mustang 5 Speed Conversion. It will handle Big Block Power (600 HP) without cutting the floor boards.



- Synchronized Ratios - 2.94 1.94 1.34 1.00 .59 Overdrive - Optional overdrives available
- Dog Rings Pro Shifted Transmissions available for 7000 RPM plus shifts
- All G-Force Gear Sets have 26 spline input shafts
- Compare Gear Size at left

Parts for 5 Speed Conversion & Performance Upgrades

Bell Housings

	289, 302, 351, 5.0	Tremec Bell	\$199.00
	4.6	Tremec Bell	\$299.00
	5.0	T-5 Bell	Used \$100.00
	289, 302, 351, 5.0	Block Plate	\$65.00
	Ford Toploader to T5	Adapter	\$149.95

Ram Clutches



Part #	Type	Application	Spline	Size	Price
RAM 88794	OEM Replacement	Ford	10	10.5"	\$166.00
RAM 88794 HD	Aftermarket - Heavy Duty	Ford	10	10.5"	\$225.00
RAM 98794	Aftermarket - Power Grip	Ford	10	10.5"	\$348.95
RAM 98794 T	Aftermarket - Power Grip	Ford	26	10.5"	\$380.00
RAM 88761	OEM Replacement	GM	26	10.5"	\$149.95
RAM 98761	Aftermarket - Power Grip	GM	26	10.5"	\$332.50
RAM 98764	Aftermarket - Power Grip	GM	26	11"	\$332.50
RAM D 4148	OEM Replacement Disc	Any	26	11"	\$73.85
RAM D 4152	OEM Replacement Disc	Any	26	10.5"	\$74.25

QuickTime Bell Housings



Part #	Application	Price
RM 6020	153 T Chevy	\$389.00
RM 6022	168 T Chevy	\$459.00
RM 6023	Tremec T56 to Chevy	\$459.00
RM 6065	Small Block Ford 5.0	\$475.00
RM 6056	Big Block Ford 5.0 to Tremec TKO 500-600	\$485.00
RM 8040	Big Block Ford to Tremec T56 6-speed	\$485.00

Ford Diaphragm Pressure Plate



Ford Diaphragm Pressure Plate, replacement for 3 finger long style pressure plate. This product has less pedal pressure.

Item #	Description	Price
260465L	11" Diaphragm Pressure Plate - add a disc	\$135.95
D 1226	11" x 1 1/8" - 10 spline disc	\$73.00
D4148	11" - 26 spline disc	\$74.85
384148DF	11" - 26 spline - dual perf disc	\$169.95

Universal Hydraulic Clutch Kit



Universal Hydraulic Clutch Kit: Fits Ford & GM Transmission
 Ford front retainer must be machined to 1.370
 May purchase in a kit or separate

Item #	Description	Price
RAM7812	Hydraulic throwout bearing	\$150.00
T175-750U	3/4" Master cylinder	\$93.75
CGT0080	#3 Hyd SS Hose st-rt 30"	\$35.00
CGT0081	#3 Hyd SS Hose st-rt 12 "	\$25.00
CGT0082	#3 St / union	\$7.50
CGT0100	5/16 RH Rod end	\$5.50
CGT0101	5/16 Jam nut	\$.75
Complete Kit		\$315.00

Mustang Clutch Linkage Items



T-5 Cable Conversions 65-66	\$259.00
T-5 Cable Conversions 67-68	\$259.00
T-5 Cable Conversions 69-70	\$259.00
Hydraulic Clutch Setup 65-70	\$425.00
Fulcrum & Spacer for T-5 Bell & Mechanical Linkage	\$36.95
Clutch Equalizer Bracket for 5.0 Engines	\$65.95
Clutch Fork 5.0	\$32.50

Mustang Cross Members



65-66 T-5 Cross Member	\$149.95
67-70 T-5 Cross Member	\$149.95
65-66 Tremec Cross Member	\$169.95
67-70 Tremec Cross Member	\$159.95

Shifters



T-5 T-45 Billet Power Shifter	\$169.95
TKO 500 & TKO 600 Billet Power Shifter	\$179.95
T 56 6-Speed Shifter	\$179.95

Driveshafts & Yokes



28 Spine 1330 X-Long Yoke	\$74.95
31 Spine 1330 X-Long Yoke	\$97.00
Conversion U-Joints 1310-1330	\$21.50

[back to top](#)

Hot Rod Oil

Joe Gibbs Driven High Performance Synthetic Motor Oil

Available in 15W-50 and 10W-30 [click here to view the details](#)

\$7.95 per quart + S&H

Call to order: 704-662-5586 | 704-663-5303



Prices subject to change without notice.

Website Hosting and Website Design by McBryde Web Site Design

For technical issues e-mail webmaster@mcbryde.com